

EL3000

Longwall Shearer



Mining Height

Seam Range	2.5-5.5 m	98-217 in
------------	-----------	-----------

Power

Maximum Installed Power	2295 kW	3,600 hp @ 60 Hz
Haulage Power	2 × 150 kW	2 × 200 hp
Maximum Cutting Power	2 × 860 kW	2 × 1,380 hp @ 60 Hz

Features

Powerful Control System

State-of-the-art Ethernet communication down to I/O-level for advanced automation and monitoring.

Unique One-piece Mainframe Design

Delivers maximum protection for all modular units and designed for ease of maintenance.

Innovative Two-piece Trapping Shoe

Allows quick, easy wear part replacement for maximum uptime.

VibraGuard Continuous Online Vibration Monitoring Option

Protects equipment by warning of damage risk and predicting component wear.

Upgradeable Design

Easy upgrades during rebuilds for long, reliable service life and installation of additional performance enhancing features.



Contents

Mainframe.....	4
Ranging Arm.....	5
Hydraulic Power Pack.....	5
Haulage System.....	6
Control System.....	8
Quality.....	14
Safety.....	16
Serviceability.....	16
EL3000 Specifications.....	17
Optional Accessories.....	21
Notes.....	23



The EL3000 Shearer has been developed for medium to high seams to meet the requirements of the most demanding longwall installations in the world. The EL3000 mines seams of up to 5.50 m (217 in). It offers 2 × 860 kW (2 × 1,380 hp @ 60 Hz) of cutting power combined with haulage motors of up to 2 × 150 kW (2 × 200 hp), with a 75 kW (120 hp @ 60 Hz) pump motor. With installed power of over 2000 kW (3,600 hp @ 60 Hz) it has a production capacity of more than 5000 tonnes (5,512 tons) per hour.

Mainframe

Made for Muscle



Robust One-piece Mainframe

The unique mainframe of the Cat® shearer is one of its key features. The fabricated structure of the mainframe with cast ranging-arm hinge points results in an extremely robust design not only to meet the toughest mining conditions and ensure reliability and long service life, but also to handle even higher cutting and haulage forces in the future.

Retrofit-ready

The mainframe of the EL3000 is designed to allow retrofit of 1200 kW (1,930 hp @ 60 Hz) ranging arms and 200 kW (268 hp) haulage units. A split mainframe is available in the event of transportation limitations.

Benefits:

- High structural integrity and absorption of all cutting and haulage forces, providing maximum protection for all major units.
- Maximum protection of electrical boxes, high level of flameproof integrity
- Improved access for maintenance and ease of overhaul and repair
- Versatility of application due to fully modular construction
- Flexible and cost-effective equipment management
- Independent unit exchange and selective overhaul
- Long service life and low operational costs



Ranging Arm

Power for the Toughest Mining Conditions

With cutting power of 860 kW (1,380 hp @ 60 Hz), the EL3000 delivers world-class production in the toughest mining conditions.

Future-ready

A new 1200 kW (1,930 hp @ 60 Hz) ranging arm is under development and can be retrofitted during rebuild.

- Cutting depth of 0.85 m (2.79 ft) and 1.0 m (3.28 ft)
- Compact design for optimum coal-loading performance
- Two-speed technology and more powerful lifting cylinder
- Modularity allows fast in-situ maintenance and repair
- Improved lubrication in lower operating temperatures
- New, more robust cowl drives



Hydraulic Power Pack

Packing More Punch



The power pack has been re-engineered to provide increased functionality, optimized performance and better access to filtration units via simplified layout.

Transformer Box

- Features closed-loop control with measurement of speed, not power

Control Box

- Plug and play/easy to maintain



Caterpillar has further developed its modular haulage concept with increased power rating, gear rating, bearing life and redundancy, leading to longer overhaul intervals based on typical usage. The haulage system is a simple design capable of achieving cutting speeds of up to 32 m/min (105 ft/min), with improved reliability and longer service life. The haulage system offers:

- Simple construction, improved reliability and longer service life
- Fully proven load-sharing system
- Reduced cost

Modular Haulage

The fully modular haulage gearbox is located in the shearer mainframe and does not form part of the shearer structure.

Separation of Structural and Wear Parts

The patent-pending Trapping Shoe Ix Exchange continues the Caterpillar principle of designing products with separate structural and wear parts to allow quick and easy replacement of surfaces subject to wear.

Low Weight, Easy Replacement

The new Trapping Shoe design cuts the weight that has to be handled during replacement from more than 500 kg (1,102 lb) to less than 50 kg (110 lb) per insert, and the time required for exchange to a fraction of the previous time. Because the weight is so much lower, change out can take place anywhere along the face. Previously this work had to be done at the gate ends, where heavy lifting equipment was available.

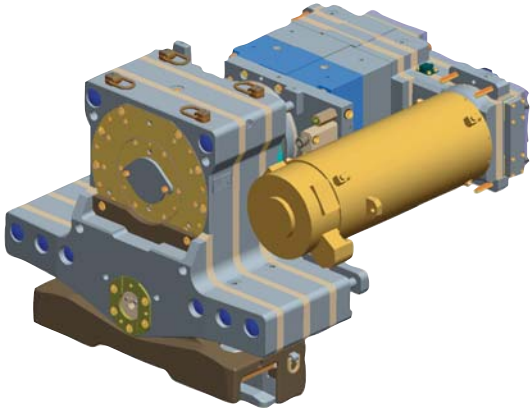

Haulage System

Modular and Innovative



Innovative Trapping Shoe

Trapping shoes attach the shearer to the haulage rack system, part of the armored face conveyor, allowing the shearer to be hauled up and down the face. The new Trapping Shoe lx advantages:

- Greater safety and ease of handling during replacement
- Faster replacement and greater flexibility
- Longer service life and lower operating costs

Control System

Industry-leading Automation

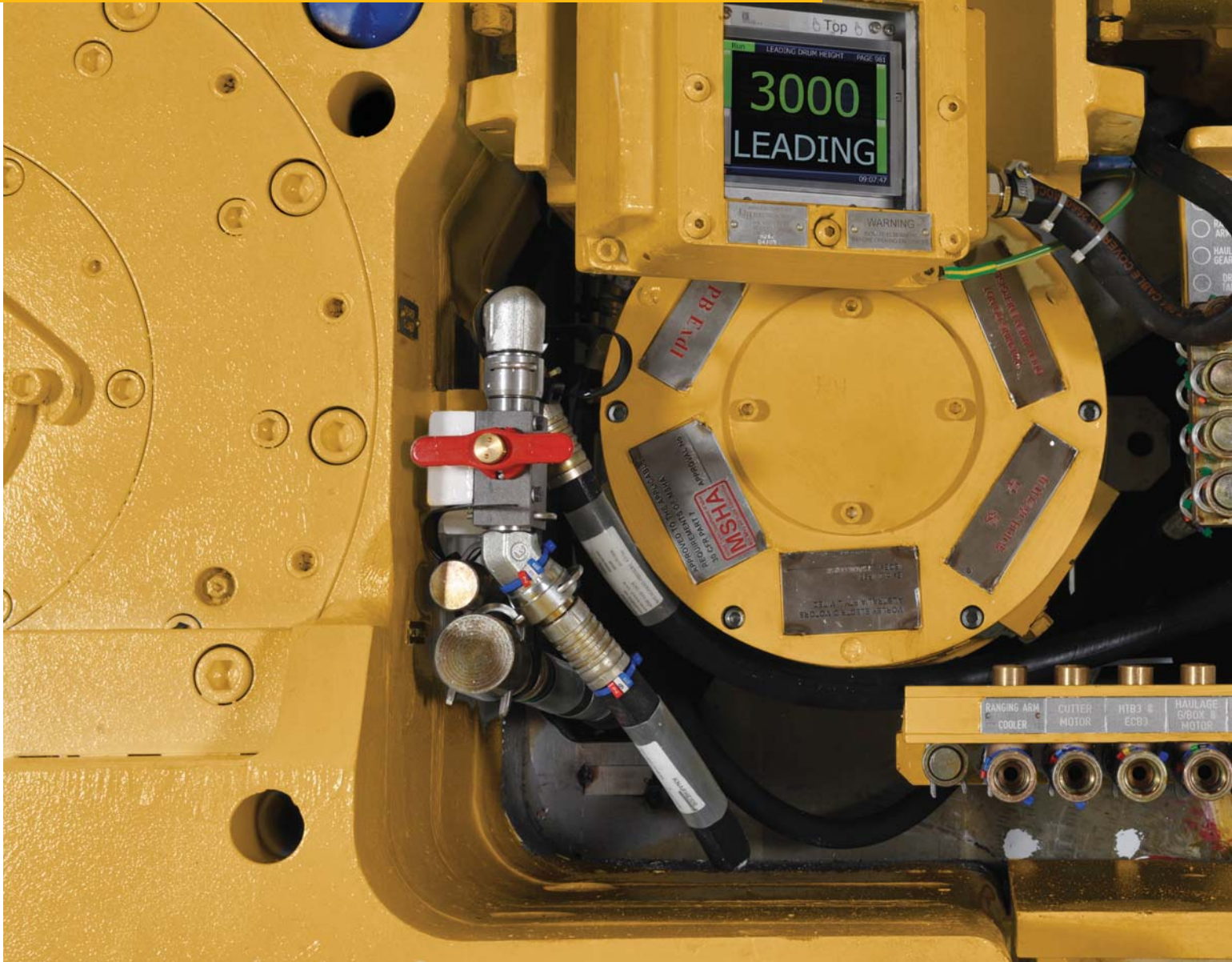

Fault Tolerance

Because of the Ethernet-based approach, the failure of one component does not impact the whole system. This allows the system to operate in the unique "fault-tolerant" mode, which allows the longwall to continue to operate when there is a problem with the overall automation system, while systematic isolation identifies faulty units while production continues.

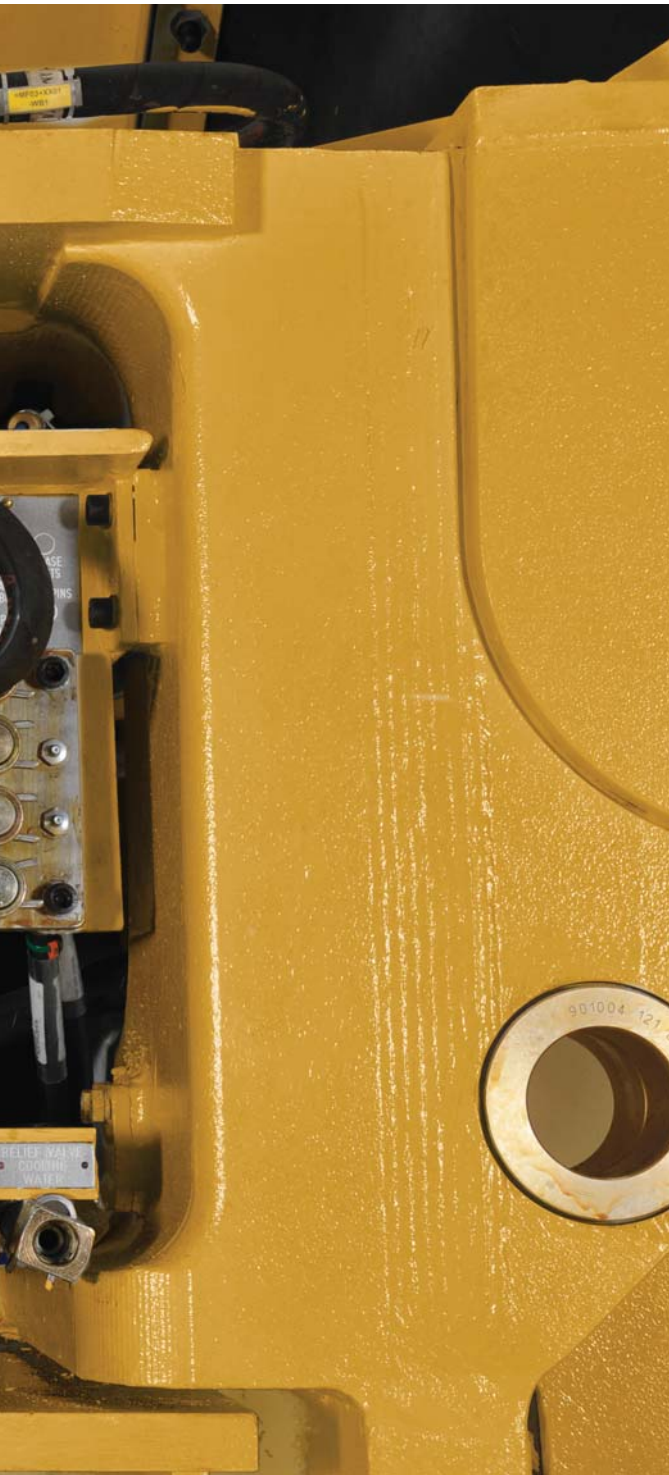

Advanced Automation

Caterpillar has developed a state-of-the-art distributed automation system for the control, monitoring and protection of the shearer. Its modular design allows it to be configured to meet individual control needs, from basic monitoring and protection to advanced automation and data transmission.

Power and Flexibility

With extensive computer power installed and simple upgrade to new features, Cat shearer automation is fit for the future. Components connect into the network rather than directly to a central computer, simplifying installation, wiring, maintenance, and troubleshooting.

Ethernet Bus

The shearer control system uses a state-of-the-art Ethernet bus, resulting in a drastic reduction in wiring and a huge increase in flexibility. There are no interfacing problems, as equipment connected to the network only needs to be able to communicate via Internet Protocol.

Self-Configuring

Commissioning, maintenance, upgrades and troubleshooting are much easier and faster, and equipment is self-configuring.

Simple Upgrade

Changes to the system only require commissioning changes – such as mounting and connection of sensors. No replacement of control software is required.

Remote Control and Diagnosis

Remote control and diagnosis are also possible down to I/O level.



Control System

Offers Flexibility and Power

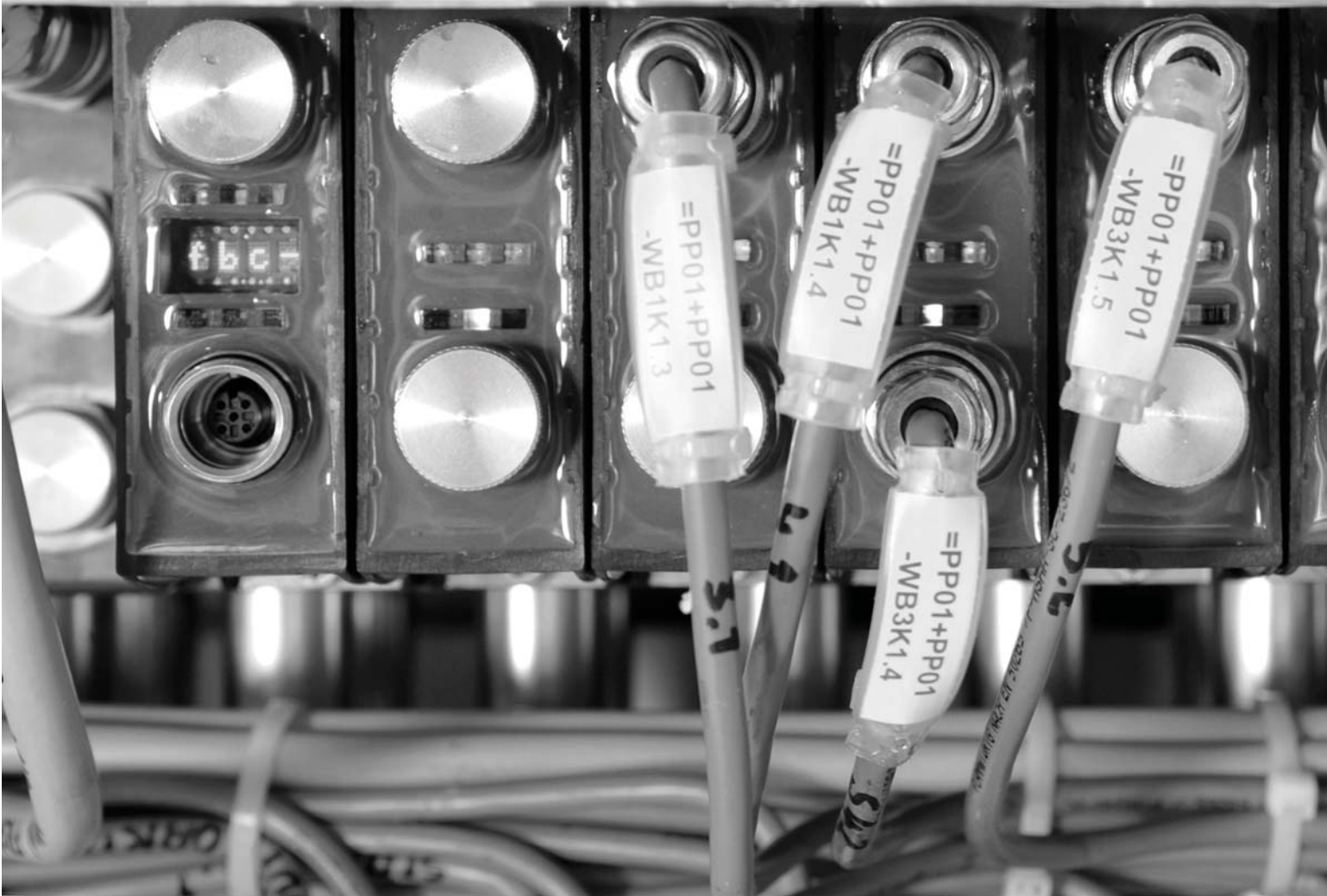

Less Maintenance Effort

Widespread use of intrinsically safe (IS) components in PMC Evo-S control system reduces time-consuming opening of flame-proof housings in the event faults. Quick and easy exchange of modules.



Modular Control

PMC Evo-S brings state-of-the-art processor performance underground.

Benefits include:

- Easily expandable based on modular design
- Ready for integration of highly sophisticated technologies and devices
- Equipped for XML-based interfaces to third- or fourth-party systems

Peak Performance

Designed by the market leader in shearer automation, the advanced Cat automation package allows improved utilization of manpower in a safe environment; with increased yield from any given seam section, faster haulage speeds, improved face management and increased life of all longwall equipment, including AFC and shields.

Scalable Automation

The degree of automation can be scaled to your needs – from basic to highly sophisticated – while remaining easy to install, operate and maintain.

Plug and Play

New modules are based on standardized CIOS modules (configurable input output system), resulting in a plug and play approach to upgrades.

No reprogramming is necessary.





PMC Evo-S offers Reliability from Day One

- Robust cables and plugs
- Minimized cabling due to network approach
- Vibration-tested components
- Designed for the working environment

Making it Easy

- Cat self-configuring controls and standard interfaces such as Ethernet allow quick and easy system configuration changes with no programming effort
- Ready for future technologies such as high-quality condition monitoring, including vibration monitoring
- Easy and flexible adaptation to existing data environments
- Greater use of Ethernet, standard connectorization and PMC control family mean greater simplicity, reduced spares inventories and shorter downtimes
- Standardization and modularization allow quick and easy customization of components and systems

Fast Troubleshooting

- Widespread use of intrinsically safe components allows large-scale fault diagnosis under power
- Remote access to most components down to I/O level
- Diagnosis from surface or by Cat Mine Control Center
- Managed switches and field bus coupler (FBC) allows selective routing:
 - Permits sequential disable and enable of components and/or communication routes
 - Isolation of faulty units until next repair shift allowing production to continue

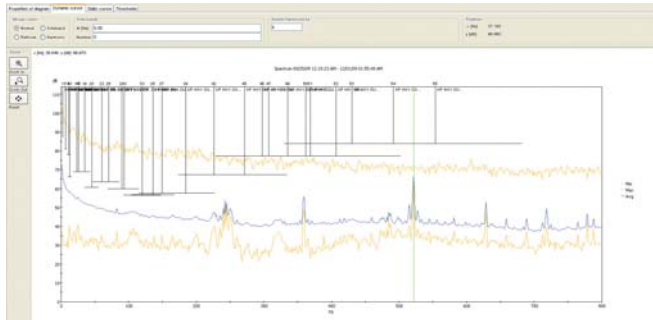

Control System

Making it Easy

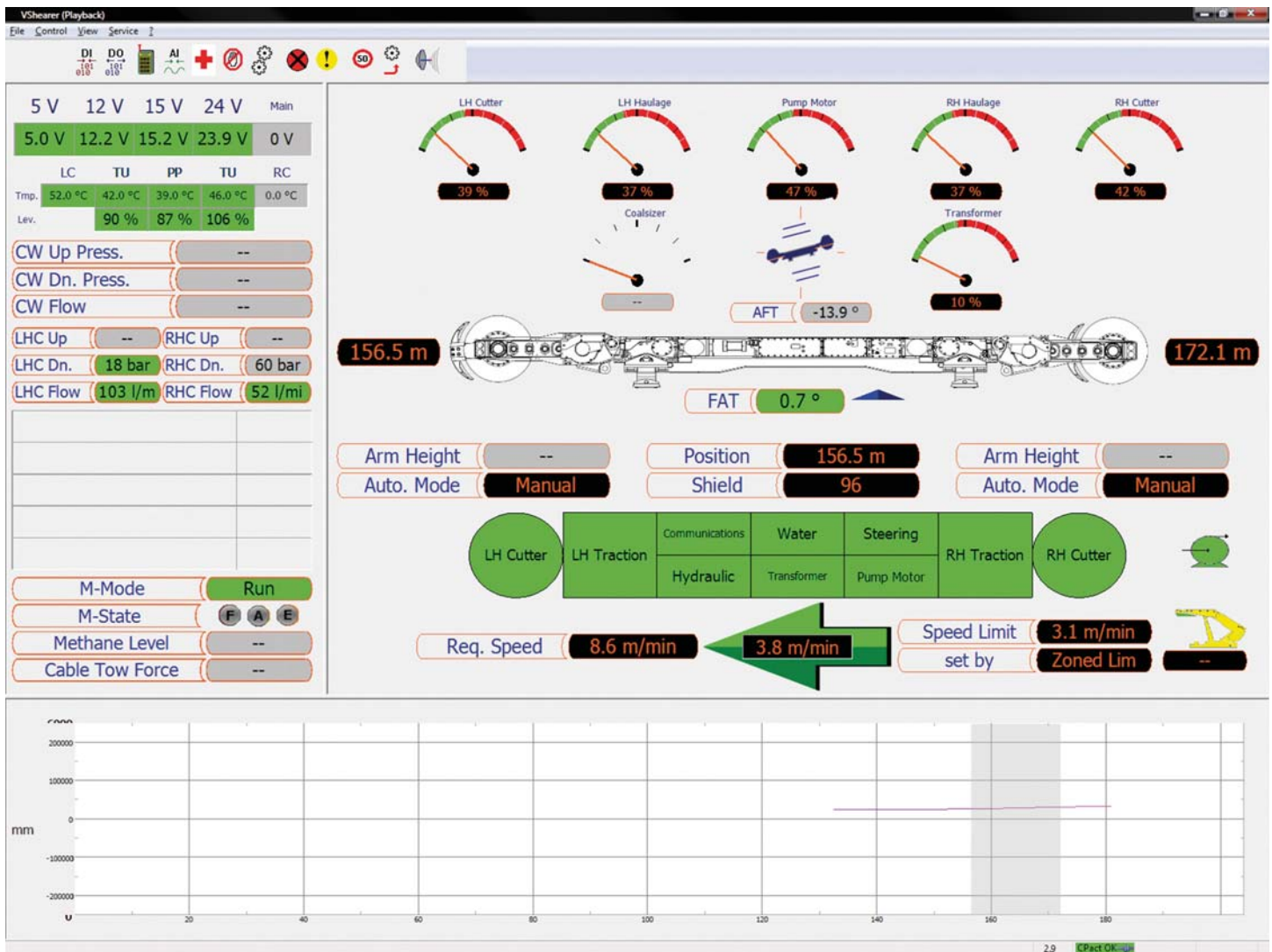

Visualization

Better Understanding of Operations – Visualization not only provides a graphical representation of current operating conditions, but can also display historical conditions and a graphic display of trends. Visualization gives operators a better understanding of the overall system, allowing them to further optimize operations.

Dedicated Applications – VLongwall provides a system overview and access to the visualization modules VShield, VDrive, VPlow and VShearer. It gives access to VTrend for trend analysis and VGraph3D for waterfall plots of the entire longwall.

Quality

Stringent Testing to Assure Highest Quality

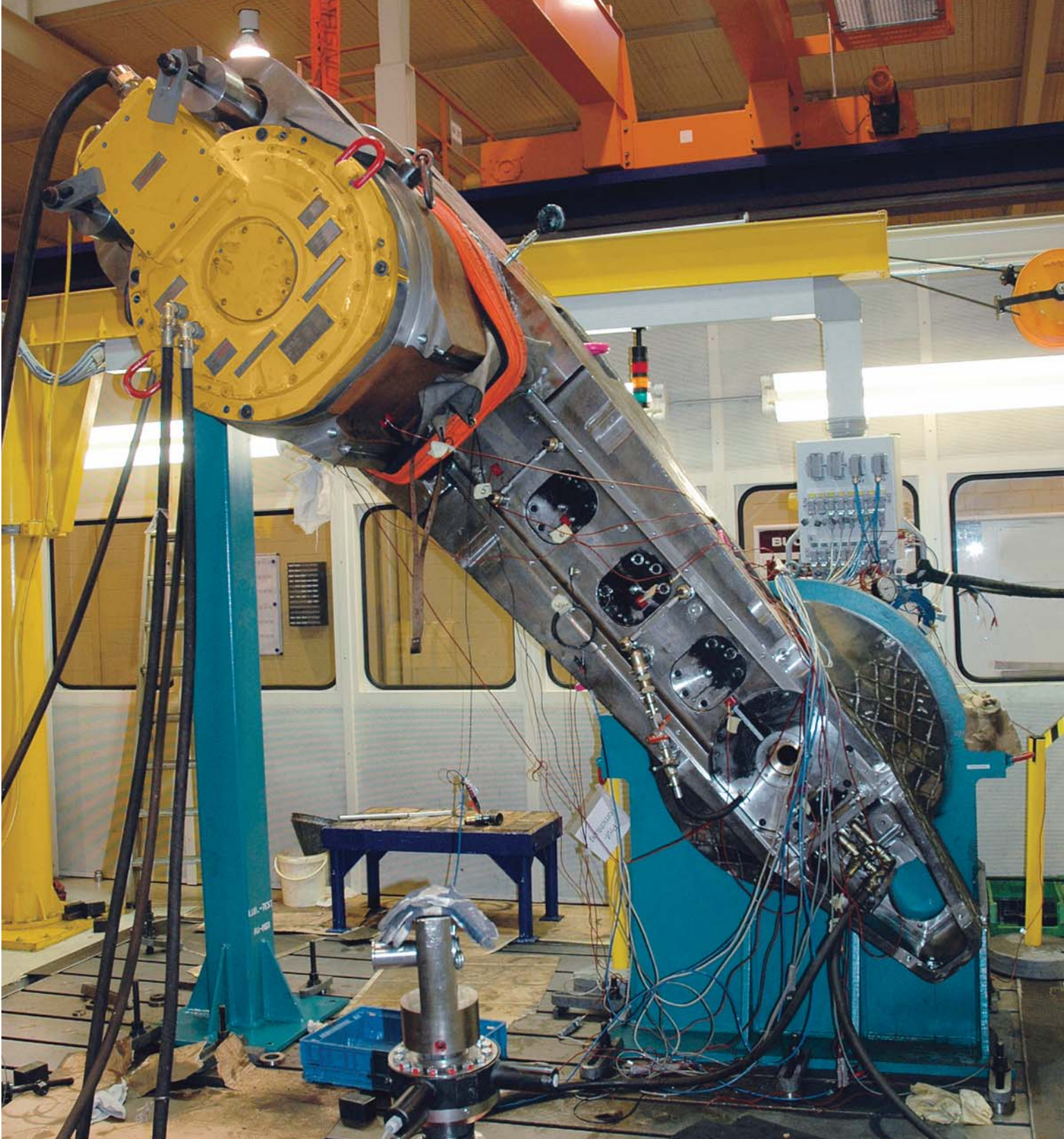

Lubrication Verification

Ranging arms and haulage units are subjected to an intense test regime to establish the optimum oil-level requirements. Tests are performed with a range of different gradients and arm positions to represent even the most severe mining conditions. The units are operated until stable temperatures are achieved at all gradients to establish minimum, maximum and optimum oil quantities for all conditions.

Endurance Testing

These tests apply loads far in excess of those encountered during normal mining operations, ensuring that the shearer can operate reliably at the installed power ratings. Loads of 100% to 175% ensure that the ranging arm design meets the requirements of the most demanding applications. Input torque, losses and output torque are monitored during the test, as are bearing, gear and shaft temperatures. Dedicated sensors monitor vibration. Oil samples are collected at intervals for analysis, as the presence of metal in the oil can indicate excessive component wear. Following the test, units are dismantled for a full internal and external inspection.

Production Load Testing

After successful endurance block load testing, the same test rigs are used to carry out production load testing of all ranging arms and haulage units. The test gradually increases the load up to full load. All temperatures and vibration points are monitored during the test, and oil samples are again collected for analysis.

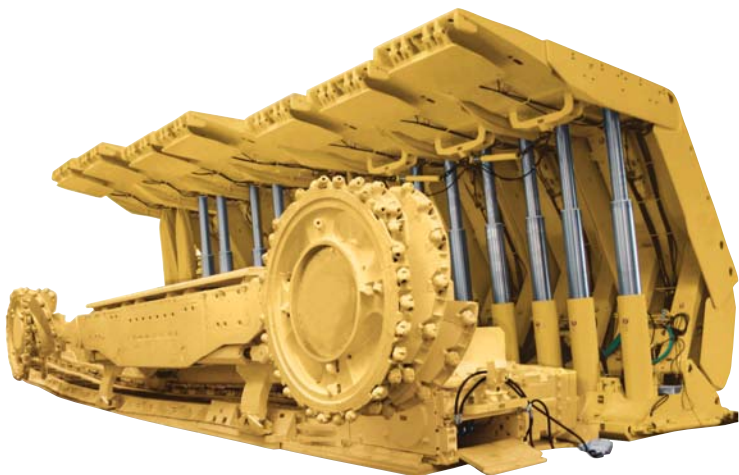

Proven Productivity

This extensive range of tests ensures the highest possible availability of shearers in service and maximum return on investment for your longwall installation. Nothing is left to chance in ensuring that Cat shearers are unsurpassed in reliability.



Serviceability

Safety

Cat shearers:
Safety is priority one

Product Safety

Caterpillar has been and continues to be proactive in developing mining machines that meet or exceed safety standards. Safety is an integral part of all machine and system designs.

Advanced Automation

State-of-the-art automation reduces the number of operators required on the face.

Safe Maintenance

Features to ease and make work underground safer are already considered in the design phase. Our unique trapping shoe with exchangeable inserts or the door handling system are engineered to make routine maintenance tasks easy and provide maximum safety.

Approvals and Safety Requirements

Cat shearers are designed in accordance to meet the most challenging underground approvals and safety requirements all around the world.

Less Maintenance Effort

- Widespread use of intrinsically safe components in PMC Evo-S reduces time-consuming opening of flameproof housings in the event of faults.
- Quick and easy exchange of modules.

Extended Service Life

Trapping Shoe inserts have the same wear area as conventional shoes and are articulated. This – combined with the fact that the shoe does not have to exert as much pressure, resulting in a lower point load – means less wear. Field tests of the Trapping Shoe Ix showed its service life to be 50 percent longer than conventional trapping shoes.

Downdrive

An innovative downdrive design results in longer bearing life, increased gear rating and greater modularity for simplified maintenance. Height adjustment of the shearer is relatively easy and is achieved with replacement of the downdrive to allow adaption to changing seam conditions.



EL3000 Longwall Shearer Specifications

EL3000 Specifications

	Machine @ 50 Hz	Machine @ 60 Hz
Seam Range	2.5-5.5 m	98-217 in
Typical Machine Length (drum centers)	15 200 mm	49.9 ft
Installed Power	Up to 2295 kW	Up to 3,680 hp
Available Cutting Power		
RA860 Arms	2 × 860 kW	2 × 1,380 hp
RA860 Arms	2 × 750 kW	2 × 1,200 hp
RA750 Arms	2 × 620 kW	2 × 1,000 hp
RA750 Arms	2 × 750 kW	2 × 1,200 hp
Cutting Drum Diameter		
RA860	Up to 2750 mm	Up to 108 in
RA750	Up to 2500 mm	Up to 98 in
Cutting Drum Speed		
RA860	30.8, 35 and 43 rpm	37, 42 and 51.6 rpm
RA750	32.8, 37.4 and 45.2 rpm	39.4, 44.9 and 54.3 rpm
Haulage System	AC inverter drive	AC inverter drive
Haulage Motor	2 × 150 kW	2 × 240 hp
Haulage Speed	Up to 31.1 m/min	Up to 98.7 ft/min
Haulage Pull	Up to 1075 kN	Up to 123 tons
Coal Sizer	200 kW	320 hp
Pump Motor	75 kW	120 hp
Body Height	685 mm	27 in
Machine Weight (approximate)	105 tonnes	116 tons
Operating Voltage	3,300V	4,160V
Minimum Pan Width	1132 mm	44.6 in

Ranging Arms

Choice of two types of ranging arm, both designed and robustly tested, for longer service life

RA750

- Transmission rating of 750 kW @ 37.4 rpm and above
- Maximum drum diameter of 2500 mm (98 in)
- Complete with 32 mm (1.3 in) bore, through shaft PFF/PBF wet cutting
- Square drum hub (440 mm [17.3 in] across flats)
- Maximum oil capacity of 28 L (7 gal) in high speed compartment and 30 L (8 gal) in the epicyclic
- Integral monitoring transducers
- Quillshaft transmission protection
- A robust cowl drive mechanism is also available on this model
- Online vibration monitoring with VibraGuard
- Available cutter motors – 620 kW and 750 kW @ 50 Hz (1,000 hp and 1,200 hp @ 60 Hz)

RA860

- Transmission rating of 860 kW @ 30.8 rpm and above
- Maximum drum diameter of 2750 mm (108 in)
- Complete with 32 mm (1.3 in) bore, through shaft PFF/PBF wet cutting
- Square drum hub (630 mm [24.8 in] across flats)
- Maximum oil capacity of 45 L (12 gal) in high speed compartment and 60 L (16 gal) in the epicyclic
- Integral monitoring transducers
- Quillshaft transmission protection
- A robust cowl drive mechanism is also available on this model.
- Online vibration monitoring with VibraGuard
- Available cutter motors – 750 kW and 860 kW @ 50 Hz (1,200 hp and 1,380 hp @ 60 Hz)

Haulage Units – HU150

- Maximum power rating 150 kW (204 hp)
- Integral water cooling @ 9 L/min (2 gal/min)
- Transmission reduction of 137:1
- Available with Machine Position Encoder
- Available with Machine Parking Brake
- Maximum oil capacity of 25 L (7 gal)
- Integral monitoring transducers
- Quillshaft transmission protection
- Online vibration monitoring with VibraGuard
- This unit has a haulage motor rating of 150 kW (204 hp)

Downdrive – DD150

- Innovative and unique downdrive design
- Transmission rating of 150 kW (204 hp)
- Maximum haulage pull 1075 kN (123 tons)
- Fully removable, rehandable, modular gearbox
- Removable modular top drive wheel assembly (cartridge)
- Downdrive ratio 22T—31T—11T (two wheel configuration)
- Available with three wheel configuration (27T idler)
- Trapping shoe with replaceable wear inserts, safe and easy to replace (Unique to Caterpillar)
- Suitable for all current rack type systems

EL3000 Longwall Shearer Specifications

Powerpack – PP3

- Fixed displacement pump, with a capacity of 200 L/min (53 gal/min)
- Operating system pressure of 210 Bar (3,046 psi)
- Robust hydraulic reservoir of 300 L (79 gal) capacity
- Integral monitoring transducers
- For use with ISO 68 or ISO 100 hydraulic oils
- Available with 6 or 8 section valve bank (dependent on function requirement)
- Available with two speed ranging arm facility
- This unit has a pump motor rating of 75 kW @ 50 Hz (120 hp @ 60 Hz)

Mainframe – MF3

- High structural integrity and absorption of all cutting and haulage forces, providing maximum protection for all major units
- Maximum protection of electrical boxes, providing the highest level of flameproof integrity
- Improved access for maintenance and ease of overhaul and repair
- Versatility of application due to fully modular construction
- Four machine heights available – 1690 mm, 1950 mm, 2110 mm and 2240 mm (66.5 in, 76.8 in, 83 in, and 88.2 in)
- A split mainframe is available in case of transportation limitations

Hydraulically Activated Top Guards

- This shearer can be equipped with hydraulically activated top guards

Electrical Control Box – ECB3

- This flameproof module contains the majority of the shearer electrical control and power distribution components
- High current carrying capacity of 500 amps and can accommodate trailing cables up to 240 mm² (9.4 in²)
- All internal chassis can be ‘bench built,’ tested and stored
- Box contains various LV circuit breakers which can be reset through the FLP cover, reducing downtime
- An extremely powerful PMC Evo-S control system with state-of-the-art Ethernet communication and backup functionality, this allows the shearer to be operated even if the overall control system is not functioning
- This unit also contains cutter motor contactors, circuit breakers, control transformer, current monitoring, HV fuses, earth leakage and both visible disconnects

Haulage Transformer Box – HTB3

- This flameproof module contains the main 350 kVA haulage transformer, power supplies, auxiliary transformer, drive system circuit breaker and two 200 kW, 600V AC inverter drives, with regenerative braking module

Electrical Material

- This model of shearer is available with headlights, cameras, methane monitoring, end displays and audible alarms
- All electrical material is designed and certified to IEC standards and also complies with other regional and national standards, such as MSHA, GOST, MA, ATEX and DGMS, as well as Australia’s New South Wales and Queensland regulations

Hydraulic Material

- All hose assemblies are to ISO 6805 and proof tested to EN ISO 1402
- The hoses are assembled to Hose Assembly Standard DIN20066:201-10
- All hose and hosing, is in compliance with guideline MDG 41 and MSHA regulations

Water Material

- All hose assemblies are to ISO 6805 and proof tested to EN ISO 1402
- The hoses are assembled to Hose Assembly Standard DIN20066:201-10
- All hose and hosing, is in compliance with guideline MDG 41 and MSHA regulations
- This model of shearer is available with onboard filtration, dust suppression spray bars, shearer clearers and ranging arm spray rings

Machine Automation and Communication

- Industry-leading Automation from the Pioneer of State-based Automation.
- This shearer has a state-of-the-art distributed automation system for the control, monitoring and protection of the shearer. Its modular design allows it to be configured to meet individual control needs, from basic monitoring and protection to advanced automation and data transmission.
- The PMC Evo-S control system with state-of-the-art Ethernet communication and backup functionality allows the shearer to be operated even if the overall control system is not functioning.
- The shearer is equipped with a state-of-the-art industry PC in a flame-proof housing with plenty of computing power, allowing flexibility to upgrade to future features such as condition monitoring.
- A Programmable Logic Controller (PLC) takes care of basic machine control tasks, ensuring that coal is produced.
- Unlike competitor systems, the modularity of the longwall system and control allow the longwall to operate in “fault-tolerant” mode, even when there is a problem with the overall automation system. In other words, integrated automation does not prevent control via individual PLC’s in order to keep production up and running.
- Levels of automation:
 - Zone-based automation “Navigator 1”
 - State-based shearer automation “Navigator 2”
 - Integrated longwall automation with “Navigator 2 + 3”
 - “Longwall Navigator” for improved face alignment and horizon control

Dimensions

All dimensions are approximate.

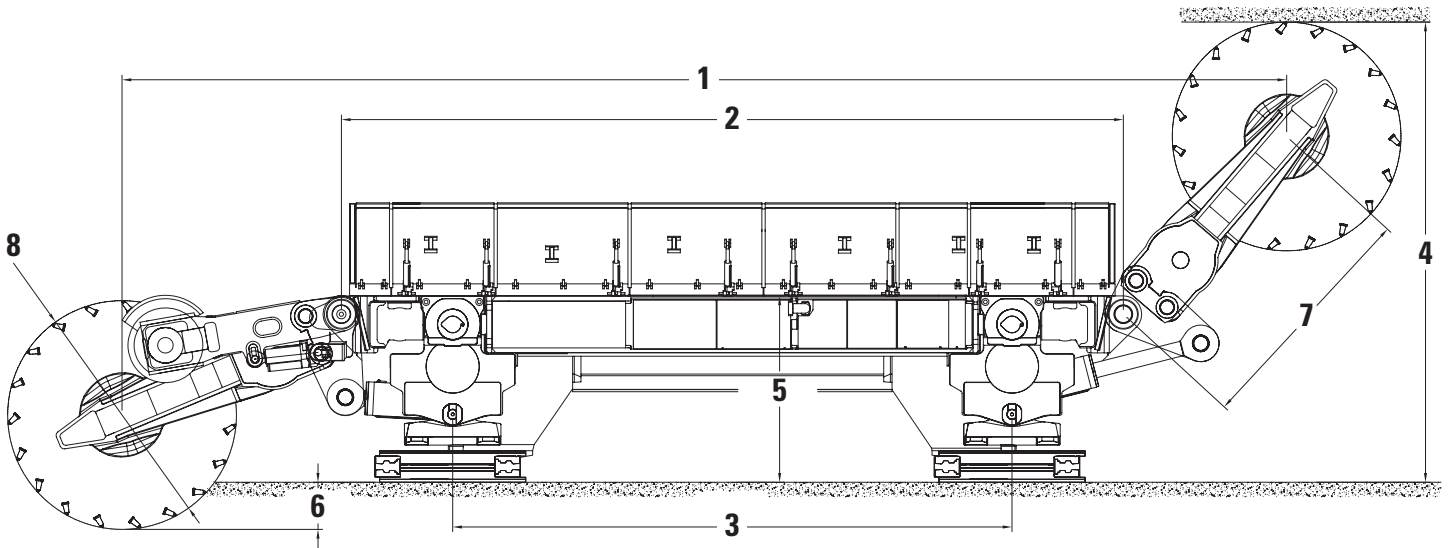

1 Distance between Drums with Arms Horizontal	15 200 mm	598 in
2 Distance between Ranging Arm Hinge Points	9400 mm	370 in
3 Distance between Trapping Shoe Centers	6724 mm	265 in
4 Maximum Cutting Height for Seam	5532 mm	218 in
5 Height to Top of Machine Main Body	2240 mm	88 in
6 Shearer Drum Undercut of Floor	567 mm	22 in
7 Ranging Arm Length (Hinge to Drum)	2900 mm	114 in
8 Diameter of Shearer Cutting Drum	2750 mm	108 in

EL3000 Longwall Shearer Specifications

Dimensions

All dimensions are approximate.

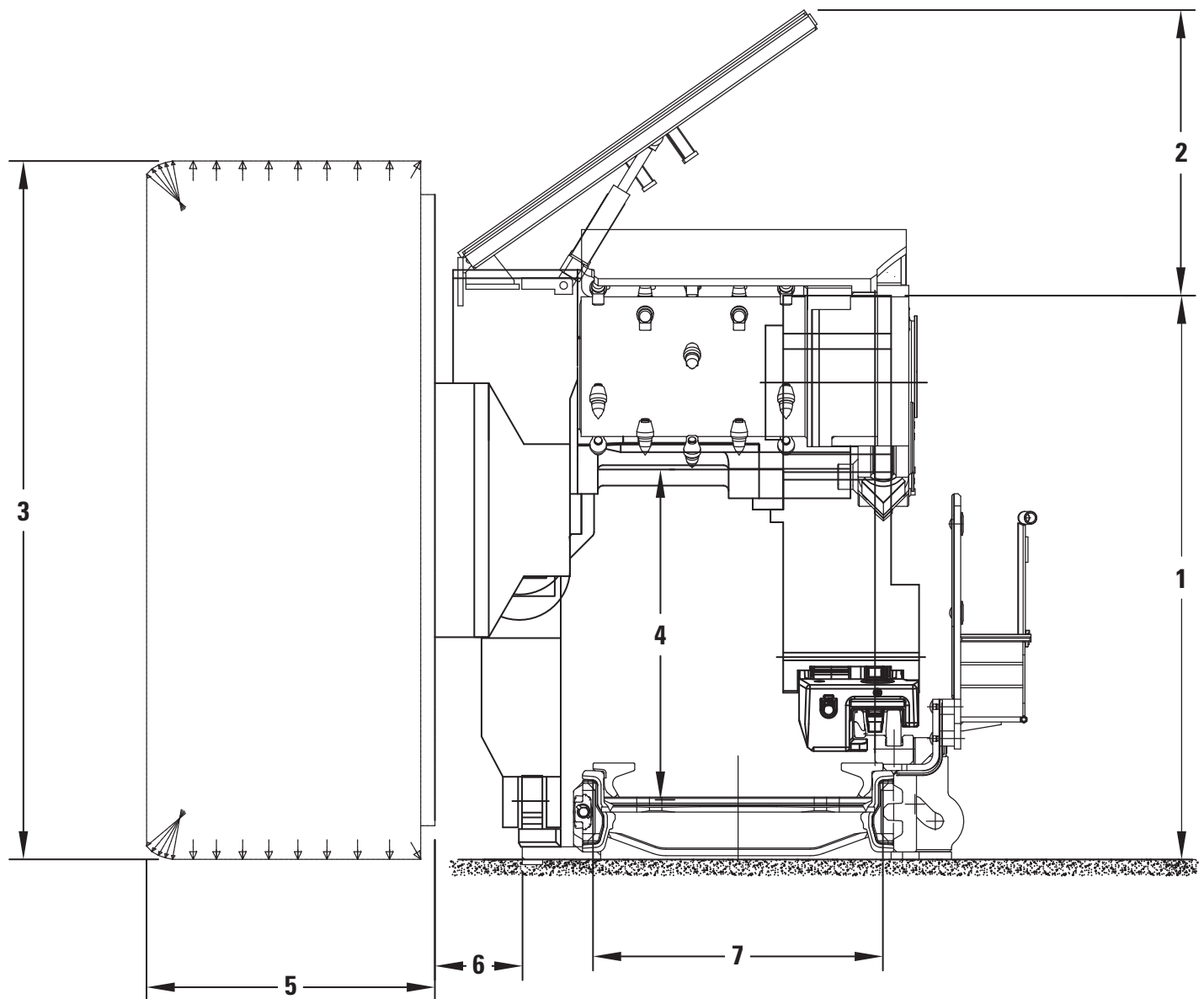

1 Machine Height over Main Body	2240 mm	88 in
2 Top Guard Height over Main Body	1124 mm	44 in
3 Ranging Arm Cutting Drum Diameter	2750 mm	108 in
4 Vertical Tunnel Clearance	1300 mm	51 in
5 Cutting Drum Overall Width	1100 mm	43 in
6 Clearance from Drum to AFC Toeplate	344 mm	14 in
7 AFC Pan Width	1142 mm	45 in

Optional Accessories

Optional Accessories may vary. Consult your Cat dealer for details.

AVAILABLE FOR EL3000:



- Multi-piece Mainframe
- Cowl
- Spall Guards
- Coal Sizer 100 kW (134 hp)
- Coal Sizer 200 kW (268 hp)
- Trapping Shoe Ix (Standard)
- Shearer Clearer
- Spray Bars
- Central Lubrication System (Standard)
- PMC Evo-S (Standard)
- Gate End Data Connection
 - Powerline (Standard)
 - Fiber Optics
 - WLAN (Standard)
- IPC
- Zone-based Automation “Navigator 1”
- State-based Automation “Navigator 2”
- Integrated Longwall Automation with “Navigator 2 + 3” (only with Cat Longwall equipment)
- “Longwall Navigator” for Improved Face Alignment and Horizon Control Incorp. LASC Tech. (only with Cat Longwall equipment)
- VibraGuard
- Cameras
- Condition Monitoring

HEALTH MONITORING

- A comprehensive health monitoring system is available, including oil levels and temperatures, flows, pressures and vibration analysis.

VIBRAGUARD™

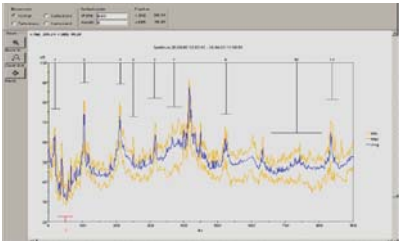

- VibraGuard allows trained personnel to predict machine component wear, avoid unplanned downtime and set alarms to warn the operator if monitored machine components run the risk of damage. This comprehensive protection backs long life and high availability of your valuable mining equipment.
- Permanent online monitoring
 - Replacing sporadic offline measurements, permanent online monitoring provides extensive protection and helps predict component wear. Alarms warn the operator if monitored components are at risk of damage.
 - Reduces unplanned downtime
 - When utilized by trained personnel, VibraGuard makes repairs predictable and helps avoid unplanned downtime. This allows timely procurement of spare parts and stress-free repair.
 - Data analysis
 - Data is transferred to a surface control center PC for detailed analysis and evaluation.

Optional Accessories (cont'd)

Optional Accessories may vary. Consult your Cat dealer for details.

COAL SIZER



Cat shearers can be supplied with an optional rugged coal sizer, currently with up to 200 kW (268 hp) of installed power for maximum productivity in high seams or difficult mining conditions. The coal sizer can be ordered separately for installation during rebuild or overhaul.

Optional Machine Mounted Coal Sizer – CS200

- Transmission rating of 200 kW (320 hp @ 60 Hz)
- Quillshaft transmission protection
- Drum speed of 200 rpm (240 @ 60 Hz)
- Drum diameter 900 mm (35.5 in) over picks
- Integral water cooling for transmission and motor
- Square drum hub drive for drum
- Complete with anti-shock lift mechanism (unique to Caterpillar)
- Available motor rating 200 kW @ 50 Hz (320 hp @ 60 Hz)

SPECIALIZED SHEARERS

Caterpillar also supplies shearers for specialized applications:

- Single- and double-drum low-seam shearer
- Three-drum shearer for selective mining

These shearers utilize the key feature of modular mainframe construction and are proven for coal and non-coal applications.

For more complete information on Cat products, dealer services, and industry solutions, visit us on the web at www.cat.com

AEHQ6800-01 (03-2013)
Replaces AEHQ6800

© 2013 Caterpillar Inc.
All rights reserved

Materials and specifications are subject to change without notice. Featured machines in photos may include additional equipment. See your Cat dealer for available options.

CAT, CATERPILLAR, SAFETY.CAT.COM, their respective logos, "Caterpillar Yellow" and the "Power Edge" trade dress, as well as corporate and product identity used herein, are trademarks of Caterpillar and may not be used without permission.

